

அலுவலகப் படி

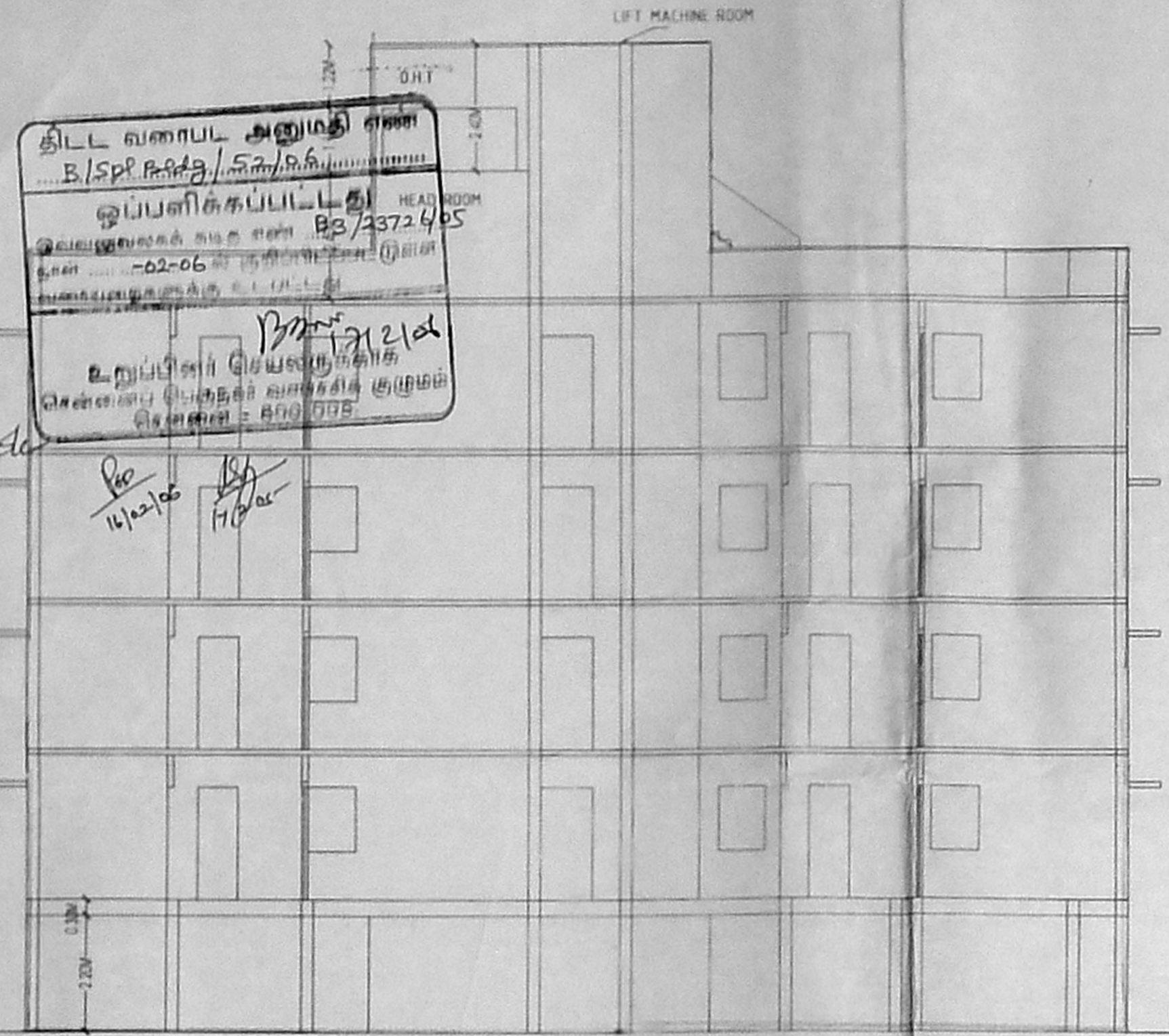

SECTION A-A



ELEVATION

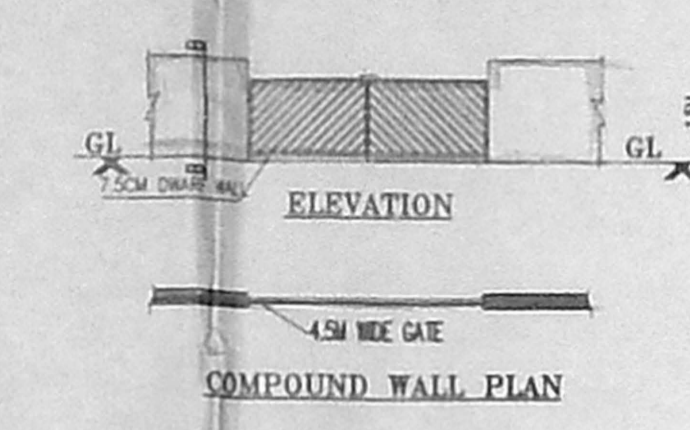

COMPOUND WALL PLAN

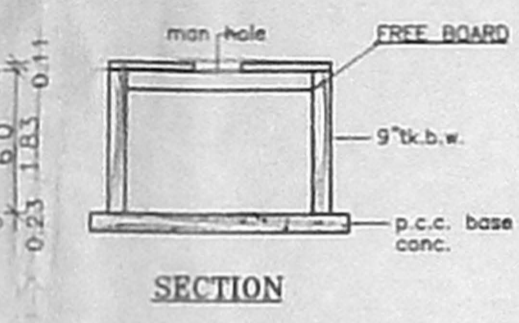

SECTION

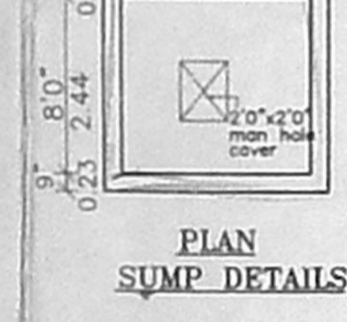

PLAN SUMP DETAILS

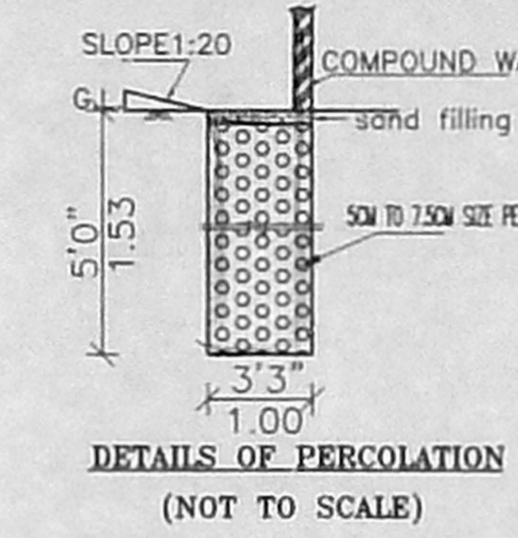

DETAILS OF PERCOLATION (NOT TO SCALE)

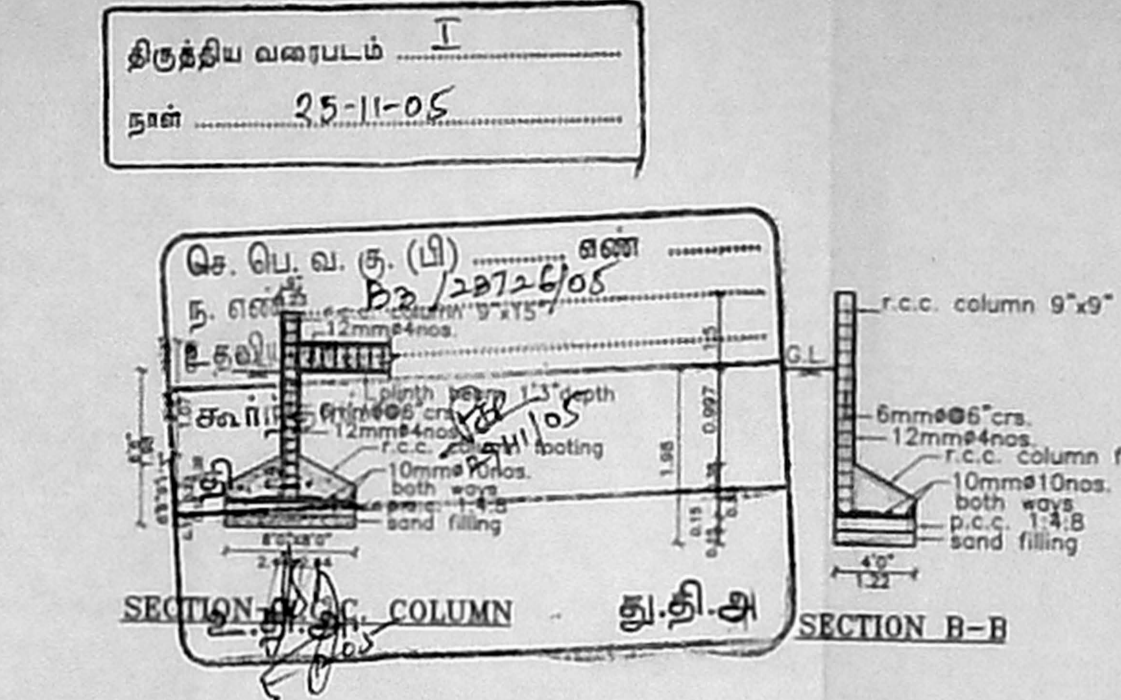

SECTION B-B

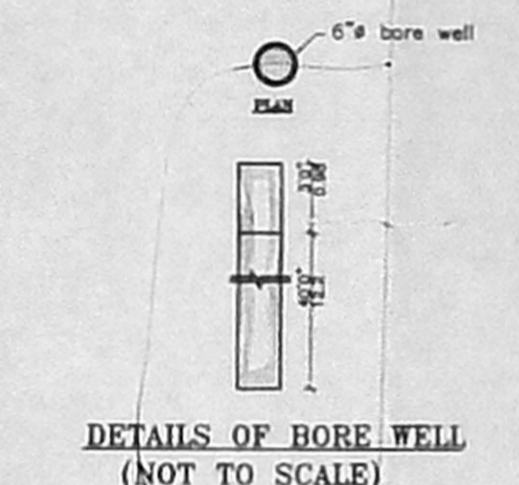

DETAILS OF BORE WELL (NOT TO SCALE)

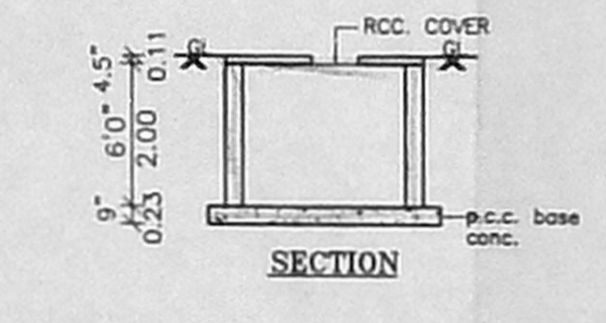

SECTION

SUMP FOR RAIN WATER HARVESTING

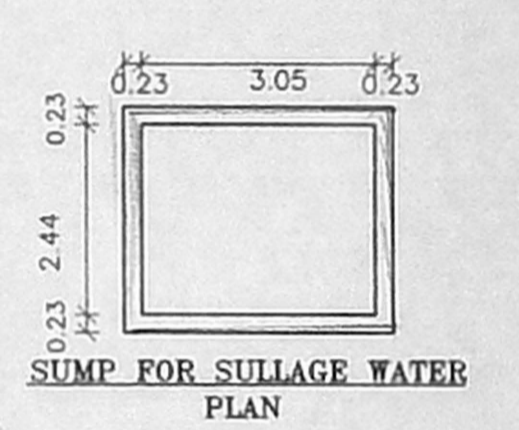

SUMP FOR SULLAGE WATER PLAN

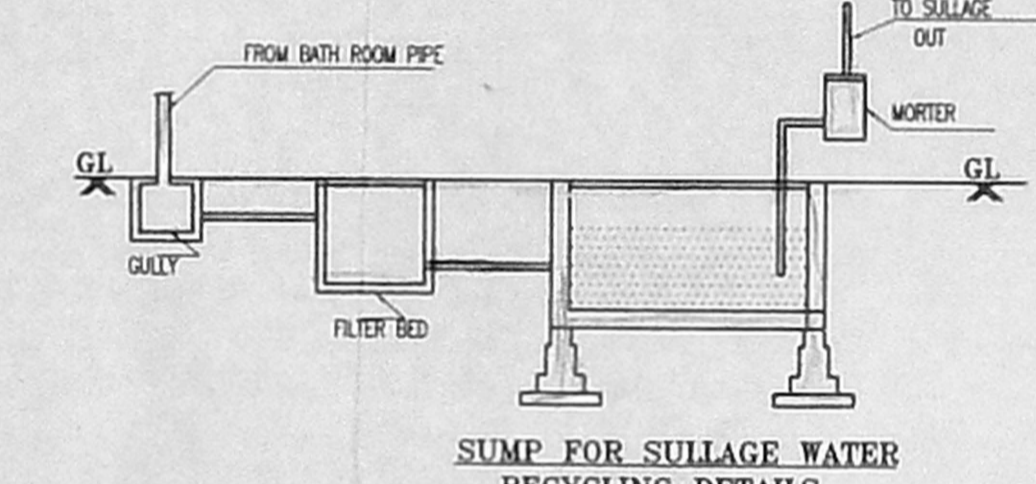

SUMP FOR SULLAGE WATER RECYCLING DETAILS

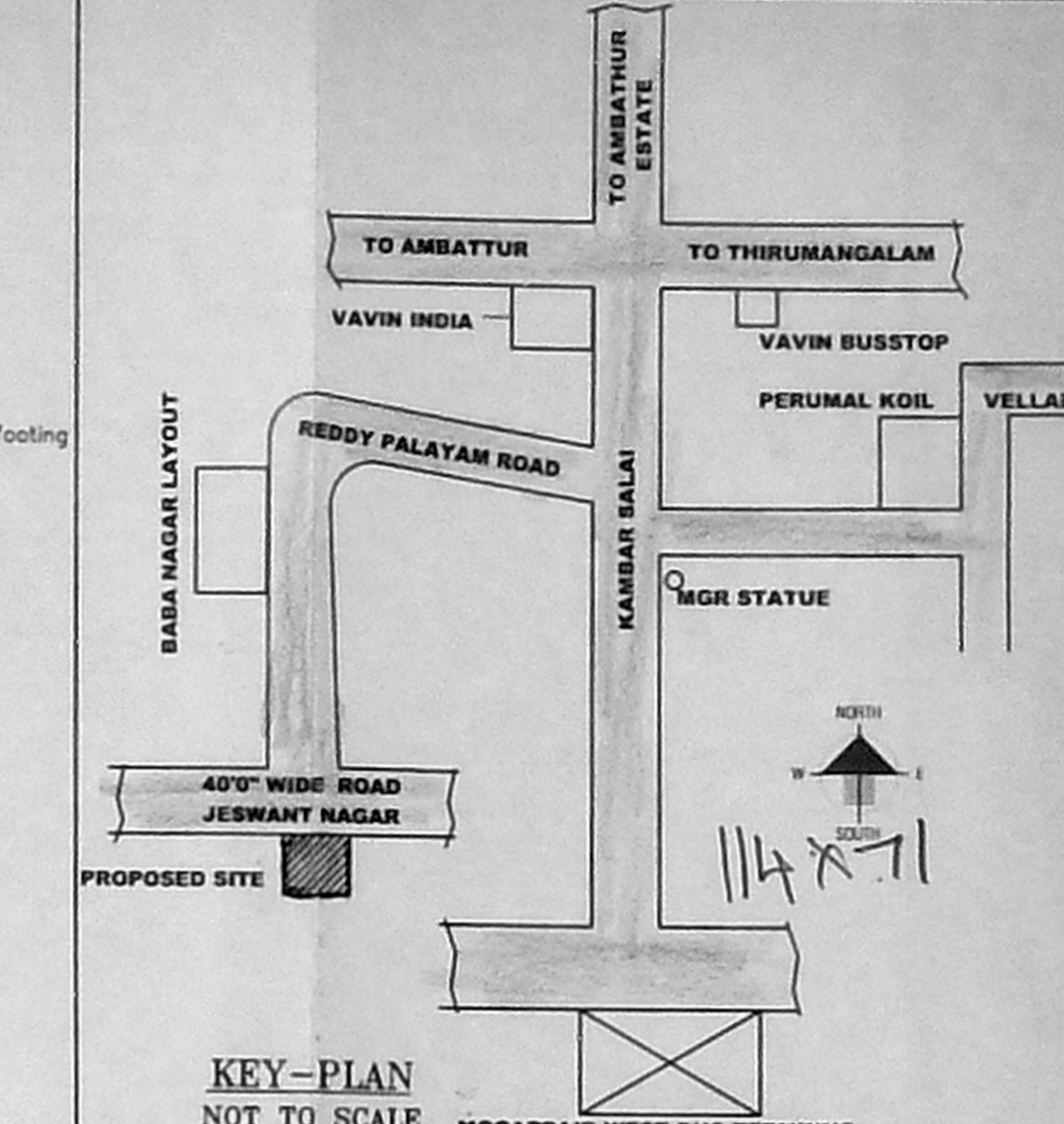

KEY-PLAN NOT TO SCALE

SAND FILLING IN FOUNDATION
P.C.C 1:4:8 IN FOUNDATION
BRICK WORK IN CM 1:5
R.C.C WORK IN 1:1.5:3 MIX
PLASTERING IN CM 1:4
WEATHERING COURSE WITH BRICK JELLY LIME CONCRETE

JOINERIES

MD	MAIN DOOR	3'3" X 7'0"	1.00 X 2.13
D1	DOOR	3'0" X 7'0"	0.91 X 2.13
D2	DOOR	2'6" X 7'0"	0.76 X 2.13
W	WINDOW	6'0" X 4'0"	1.83 X 1.22
W1	WINDOW	4'0" X 4'0"	1.22 X 1.22
W2	WINDOW	3'0" X 4'0"	0.91 X 1.22
V	VENTILATOR	2'0" X 2'0"	0.61 X 0.61
O	OPENING	3'0" X 7'0"	0.91 X 2.13

AREA DETAILS

	SQ.FT.	SQ.MT.
PLOT EXTENT	11302.10	1050.00
STILT FLOOR	172.00	15.98
FIRST FLOOR	4173.53	387.69
SECOND FLOOR	4173.53	387.69
THIRD FLOOR	4173.53	387.69
FOURTH FLOOR	4173.53	387.69
TOTAL	16866.12	1566.74

F.S.I = 1.492
PLOT COVERAGE = 36.92%
CAR PARKING = 8 Nos. SCOOTER PARKING = 12 Nos.

REFERENCE
PROPOSED
ROAD
BOUNDARY

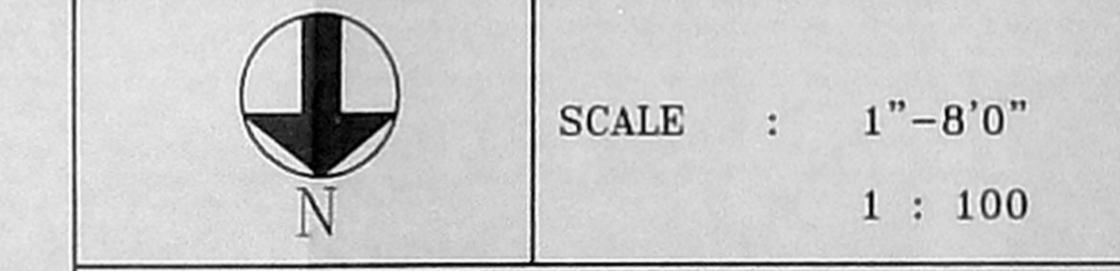

PLAN SHOWING THE PROPOSED CONSTRUCTION OF RESIDENTIAL BUILDING AT PLOT No.11A , 11B, 12A, 12B, IN S.No603/16A2 & 603/17B OF MOGAPPAIR VILLAGE, AMBATTUR TALUK, THIRUVALLUR DIST. CHENNAI - AMBATTUR MUNICIPALITY

(POWER AGENT OF Mrs.NISHA MADAN)
OWNER'S SIGNATURE

S. ATHYAN, B.E.,
CIVIL & ARCHT. ENGINEER,
Class II License Surveyor No. 192
5, Nallur Street, T. Nagar,
Chennai-17. Ph: 2615624
Mobile: 91628440.
LICENSED SURVEYOR

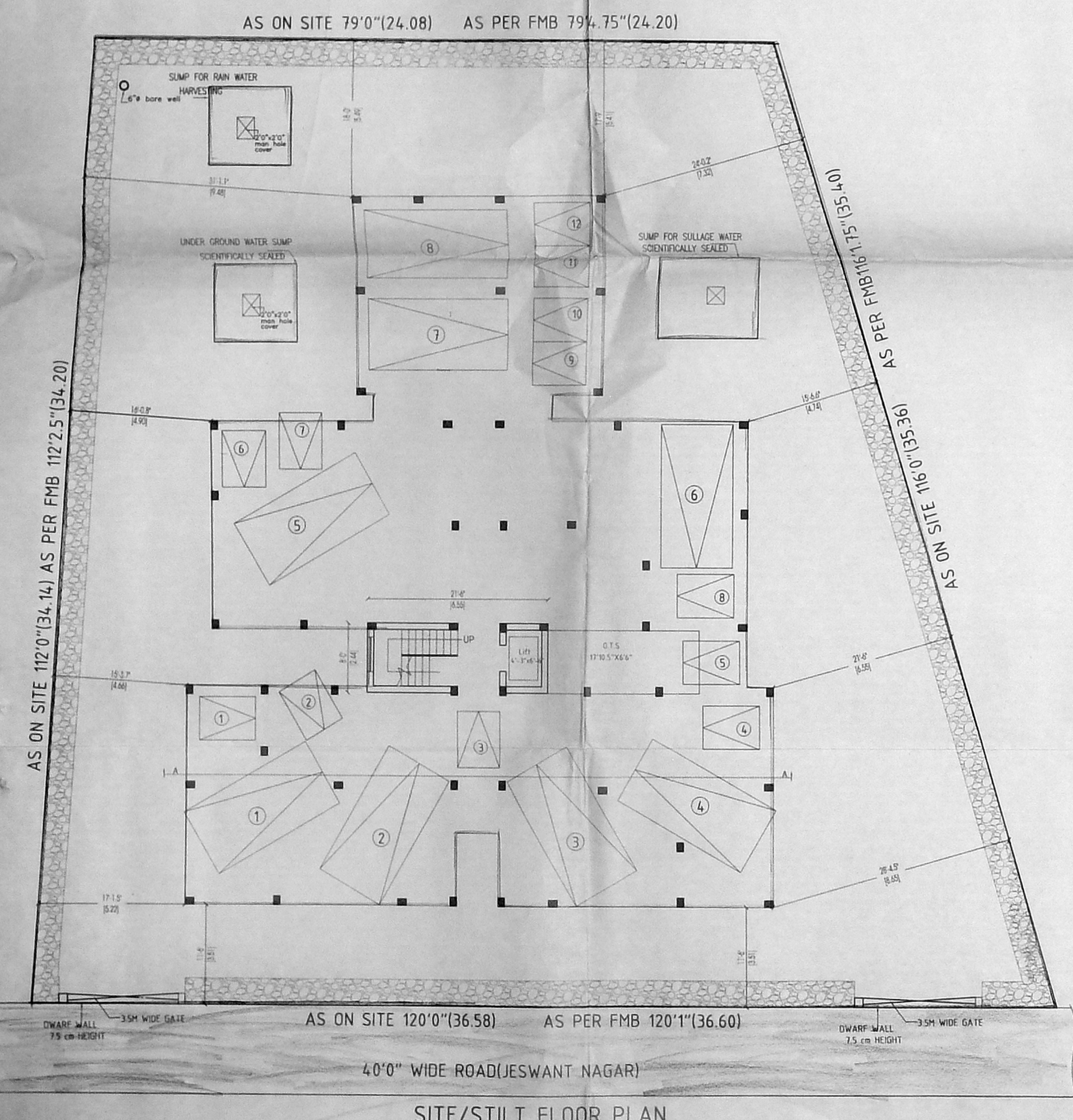

SITE/STILT FLOOR PLAN

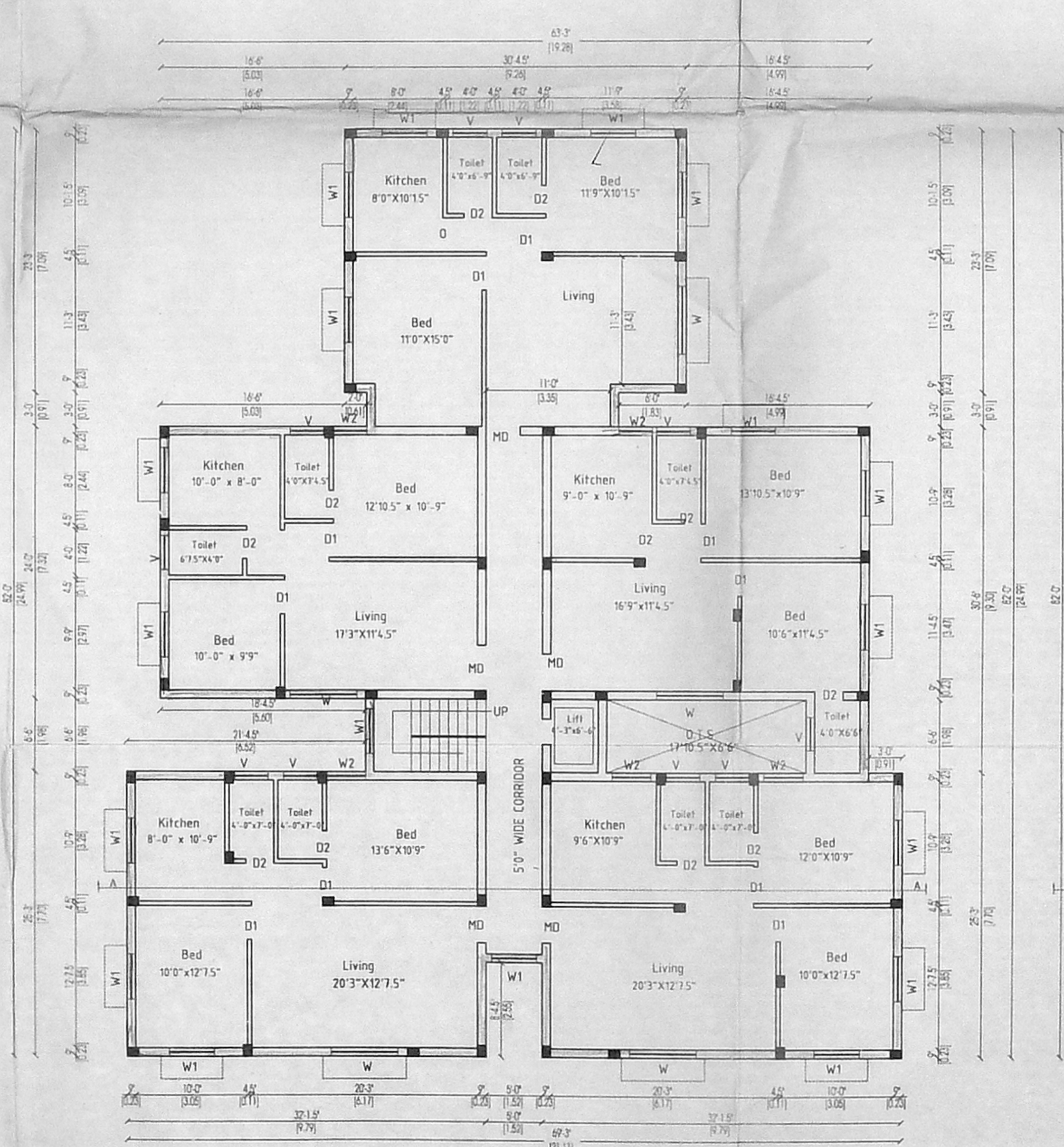

TYPICAL FLOOR PLAN
FIRST, SECOND, THIRD & FOURTH FLOOR

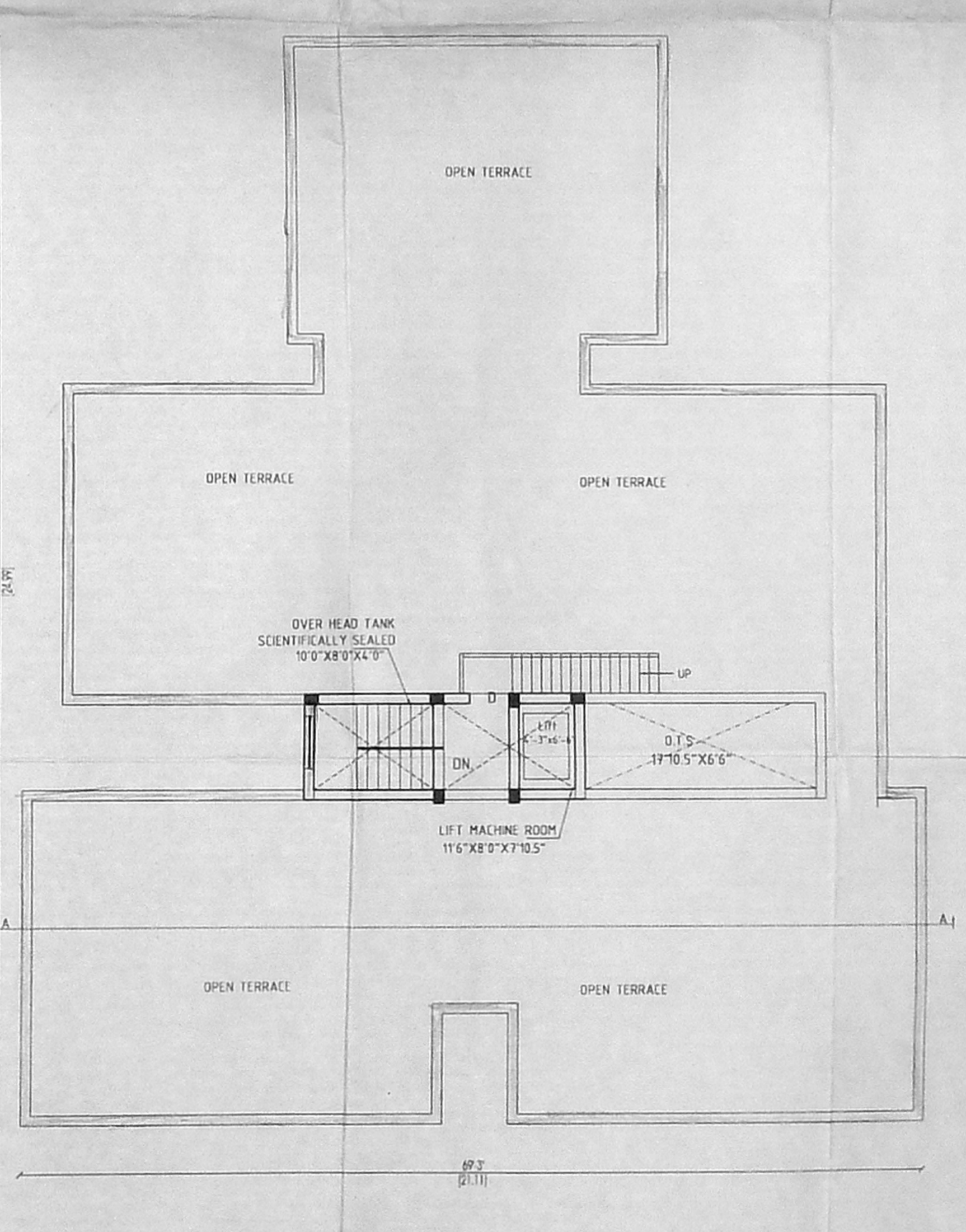

TERRACE FLOOR PLAN